

Logistec



Logistec 1520/1200 Electric Straddle Stacker

Electric Stacker With Smallest Working Space Needed
Innovative Design of Low Energy Consumption and High Reliability
Long & Aside Tiller Design Makes Operations Safe and Convenient

Logistec 1520/1200 Electric Straddle Stacker

Performance



- Robust Structure.
- Highly specialized drive and hydraulic system ensure excellent driving performance and high reliability.
- Low-noise and durable hydraulic unit, high quality cylinder as well as hose ensure high reliability of hydraulic system.
- AMP connector and durable electric wires greatly reduce malfunctions of components.
- Straddle Chassis option offers stability of high stack operation.

Safety



- Safety hydraulic design prevents mast from falling down abruptly when oil pipes cut off.
- Belly button prevents truck from hitting operator.
- By simply pressing emergency disconnecter, power supply will be immediately interrupted.
- Multi lifting limited switch ensures travel safety.
- Truck automatically switches to low speed mode, when lifting height is higher than setting height.
- Anti-rolling back braking device ensures trucks don't roll back on ramps.

Operation



- Ergonomic tiller head for effortless and comfortable operations.
- Tiller with long arm for smooth steering.
- Compact chassis design offers smallest turning radius needed.
- Side operating ensures excellent visibility.
- On-board Charger.

Maintenance



- Maintenance-free Battery.
- Battery display indicator with hour meter, reminds operator of charging on time (optional).
- Easy Maintenance - detachable rear panel.
- Self-Diagnostics signal on the digital display allows easy trouble-shooting.
- Easy Access of Hand Set.
- Low-voltage Cut-off Protection.

Logistec 1520/1200 Electric Straddle Stacker

Specifications

Distinguishing mark	1.1	Manufacturer			Logistec
	1.2	Model designation			Logistec 1520/1200 Straddle Stacker
	1.3	Drive			Electric
Service	1.4	Operator type			Pedestrian
	1.5	Rated capacity	q	kg	1200
	1.6	Load center distance	c	mm	600
Tyres/chassis	1.8	Load distance, Centre of drive axel to fork	x	mm	850
	1.9	Wheelbase	y	mm	1210
	2.1	Service weight		kg	543
	2.2	Axle loading, laden front/rear		kg	783/960
	2.3	Axle loading, unladen front/rear		kg	420/123
	3.1	Tyre type			Polyurethane
	3.2.1	Tyre size, front		mm	Φ210 x 70
	3.3.1	Tyre size, rear		mm	Φ100 x 50
	3.4	Additional wheels		mm	Φ100 x 50
	3.5	Wheels, number front/rear (x=drive wheels)		mm	1x +1/4
Dimensions	3.6.1	Tread width, front	b10	mm	533
	3.7.1	Tread width, rear	b11	mm	1060/1160/1260/1360
	4.0	Max. Lift Height	h	°	1570
	4.2	Retracted mast height	h1	mm	1940
	4.3	Free lift	h2	mm	1407
	4.4	Lift height	h3	mm	1510
	4.5	Height, mast extended	h4	mm	2053
	4.6	Initial lift	h5	mm	-
	4.9	Height of tiller handle in drive position min./max.	h14	mm	860/1200
	4.10	Height of wheel arms	h8	mm	100
	4.15	Lowered height	h13	mm	60
	4.16	Overall length	l1	mm	1570
	4.20	Length to face of forks	l2	mm	500
	4.21	Overall width	b1/b2	mm	1135/1235/1335/1435
	4.22	Fork dimensions	s/e/l		35/100/1070
	4.24	Fork carriage width	b3	mm	780
	4.25	Distance between fork-arms	b5	mm	200-760
4.26	Distance between wheel arms/loading surfaces	b4	mm	100	
4.31	Ground clearance, laden, below mast	m1	mm	30	
4.32	Ground clearance, center of wheelbase	m2	mm	40	
4.34.1	Aisle width for pallets 1000x1200 crossways	Ast	mm	2175	
4.34.2	Aisle width for pallets 800x1200 crossways	Ast	mm	2100	
4.35	Turning radius	Wa	mm	1329	
Perfor- mance data	5.1	Travel speed, laden/unladen		km/h	4/4.5
	5.2	Lifting speed, laden/unladen		m/s	0.12/0.22
	5.3	Lowering speed, laden/unladen		m/s	0.12/0.11
Electric- engine	5.8	Max. gradeability, laden/unladen		%	3/10
	5.10	Service brake			Electromagnetic
	6.1	Drive motor rating S2 60 min		kw	0.65
	6.2	Lift motor rating at S3 15%		kw	2.2
	6.4	Battery voltage/nominal capacity		V/ah	2x12/85
Addi- tion	6.5	Battery weight		kg	2x25
	8.1	Type of drive unit			DC
	10.5	Steering design			Mechanical
	10.7	Sound pressure level at the driver's ear		dB(A)	74

If there are improvements of technical parameters or configurations, no further notice will be given. The diagram shown may contain non-standard configurations.

Mast Options

Mast Type	Lift height h3+h13 (mm)	Height, mast lowered h1(mm)	Free lift h2 (mm)	Height, mast extended h4 (mm)
2 Standard Mast	1570	1940	1387	2053
	1920	2290	1737	2403

Options

No.	Option items	Logistec CQE15R
1.1	Fork dimension	<ul style="list-style-type: none"> ● 900*600 2A 100*40*1070 ○ 900*600 2A 100*40*1220 ○ 900*600 2A 100*40*1000 ○ 900*600 2A 100*40*1370
1.2	Leg width	● 985 ○ 1085/1185/1285
1.4	Fork carriage width	● 800mm
1.5	Fork carriage height	● No ○ 916mm
2.1	Load wheel type	● Double
2.2	Load wheel material	● PU
2.3	Drive wheel material	● PU ○ Trace PU
2.7	Battery capacity	<ul style="list-style-type: none"> ● 85Ah ○ 80Ah (Li-ion) ● 24V-10A internal ○ 24V-15A internal ○ 24V-30A internal (Li-ion)
2.8	Charger	
2.9	Battery indicator	● Without time ○ With time
2.16	Handle head type	● Hands big handle head
3.3	Castor wheels	● Yes and not customized
3.11	Rearview mirror	● No ○ Yes and not customized
3.16	Vertical handler working	● No ○ Yes and not customized

Note ● Standard ○ Optional - n/a

Rated Capacities Graph

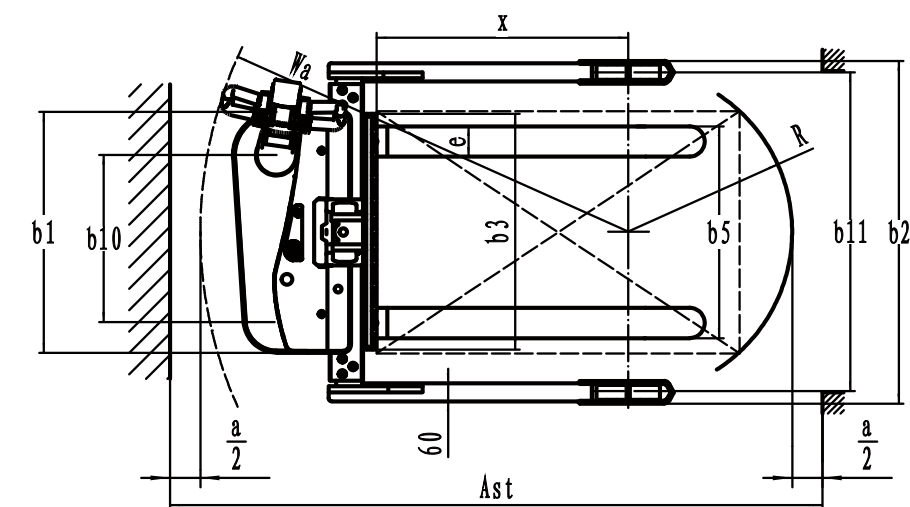
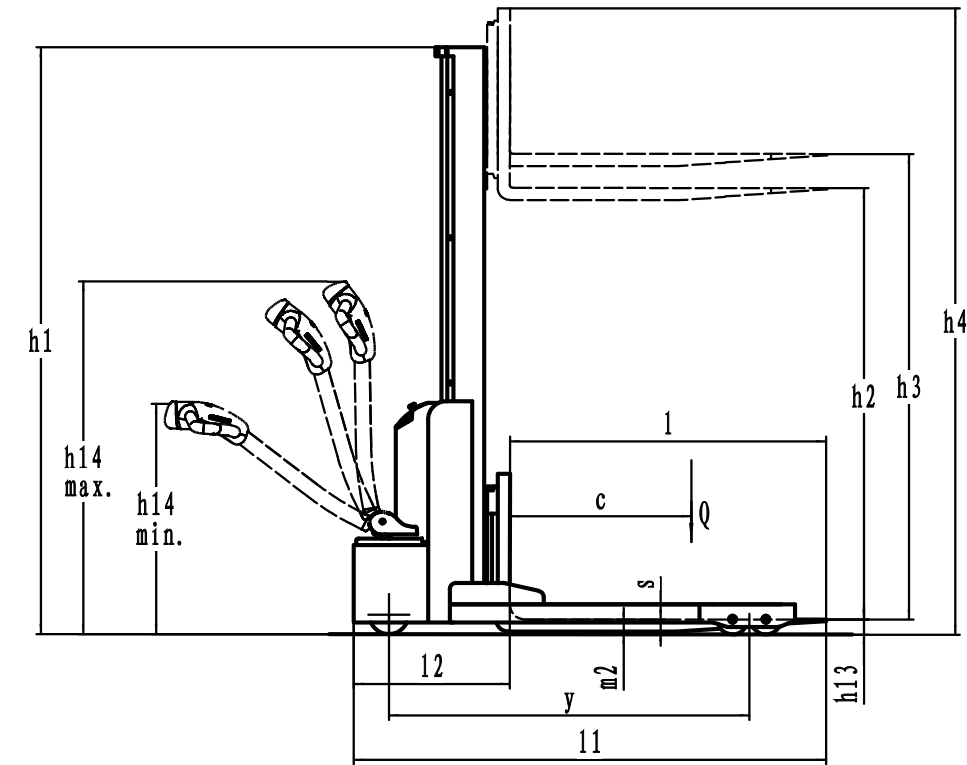
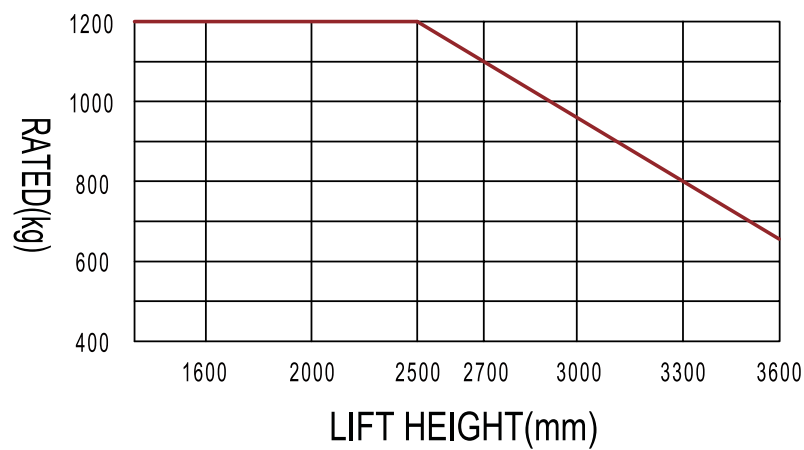



www.sitecraft.net.au | 1300 363 152 | sales@sitecraft.com.au